

VALVTECHNOLOGIES



Zero Leakage Valve Solutions

Corporate Capabilities



ValvTechnologies'
focus is to provide
ZERO LEAKAGE
VALVE SOLUTIONS

Solutions

As a global leader in the design and manufacturing of severe service valves, ValvTechnologies has established a worldwide reputation for superior quality and dependability with customers in every industry.

From standard applications to the most sophisticated, ValvTechnologies is committed to providing solutions for customers to manage their processes safely and efficiently. Our approach at ValvTechnologies is based on customer satisfaction, safety, people, process and performance. By equipping highly trained people with the latest technology, ValvTechnologies has created an atmosphere where quality and reliability are built into its products from start to finish. All of ValvTechnologies' valves are designed with customers' requirements in mind and offer proven reliability, superior engineered performance and unique safety features. By focusing on these principles, ValvTechnologies has become an integral part of its customers' asset management strategy.



Company

ValvTechnologies is a committed partner in providing solutions to manage your process – saving time, money and improving overall system efficiency.

With over twenty years of business growth, ValvTechnologies has maintained a culture of innovation by continuously expanding its design, production and technology capabilities. ValvTechnologies provides an unsurpassed level of reliability to customers in the power, mining, hydrocarbon, pulp and paper, and various specialty industries. ValvTechnologies' 90,000 square foot (27,432 meters squared) manufacturing facility features a large production area that includes a complete machining facility, and certified welding department. These departments along with a large inventory of parts and stock valves allow ValvTechnologies to have complete control of all aspects of the manufacturing process, even for the most demanding projects.

People

From engineering & design to manufacturing, our employees make the difference.

At ValvTechnologies, our employees are a valuable asset. Made up of functional teams that focus on customer service, safety, product development, quality management, assembly and testing; our staff is committed to continually developing innovative designs, production and technology capabilities. With a full staff of professional engineers, a technical sales team and certified service technicians, ValvTechnologies is more than a manufacturer – we are a partner for providing superior solutions to your process needs.



Process

At ValvTechnologies, our processes and procedures ensure that our valves exceed our customers' needs.

From raw material to the finished product, we are constantly looking for methods to apply innovative technologies to our process. While many valve manufacturers are focused on cutting corners to save costs, we remain true to our core design principles relentlessly pursuing product and process improvements that in the long term provide measurable benefits for our customers. ValvTechnologies' in-house research and design capabilities include flow testing and development of diagnostic tools for measuring energy loss. We also work directly with customers to develop solutions that meet unique process requirements and specialty applications.

Performance



ValvTechnologies sets the standard for zero leakage valve solutions.

At ValvTechnologies, we are totally committed to quality. We measure our performance against the standards set in our Integrated Quality Program. Our Quality Assurance department diligently pursues opportunities for improvement, while the entire organization takes ownership of the quality program. In this way, we can improve our processes while increasing manufacturing efficiency.

ValvTechnologies, Inc. is certified to:

- ISO 9001
- ASME Section 1
- API Q1
- PED
- NB-23

Nuclear Quality Assurance Program:

- ANSI N45.2
- 10 CFR 50 Appendix B for Nuclear Safety Related Components
- Acceptance of Part 21
- NQA-1 (Latest Edition)
- ASME "N" and "NPT" (Pending)
- Member of the Nuclear Industry Assessment Committee (NIAC)

At ValvTechnologies, we relentlessly pursue product and process improvements.

Applications

ValvTechnologies' valves are built to withstand the most severe applications. High temperature, high pressure, high cycling, abrasive, corrosive and caustic media have all been considered in the design of our product line.

ValvTechnologies provides field proven solutions for severe service applications.



Nuclear Generation

- Boiler Feedwater
- Circulating Water System
- Component Cooling
- Condensate Extraction
- Condensate Cooling Water
- Emergency Feedwater
- Fire Protection System
- HP Safety Injection
- HP & LP Heater Drains
- Heat Exchanger Vent & Drains
- Main Steam System Isolation, Drain & Vent
- Power Operated Relief Valve (PORV)
- Pressurizer Drain & Vent
- Rad Waste System
- Reactor Coolant Pump Drain & Vent
- Reactor Head Vents
- Reactor Water Cooling Vents & Drains
- Safety Injection System
- Secondary System Isolation, Drain & Vent
- Service Water System Isolation
- Steam Generator System
- Turbine By-pass
- Turbine Drain & Vent

Fossil Fuel

- Above & Below Seat Drains
- Ash Handling
- Attemperator Spray Control
- Boiler Drains
- Boiler Feed Pump Isolation
- Continuous Boiler Blowdown
- Electronic Relief
- Feedwater Heater Drains
- Feedwater Isolation
- Instrument Isolation
- Main Steam Stop
- Recirculation
- Seal Steam Regulators
- Sight / Gauge Glass Drains
- Soot Blower Regulators
- Startup Vents
- Steam Dump
- Turbine Bypass Systems
- Turbine Drain

Oil & Gas Production

- Wellhead Choke Isolation
- HIPPS
- Emergency Shutdown
- Compressor Recycle & Isolation
- Sour Gas Isolation & Control
- Steam, Water & Gas Injection
- Steam Chokes
- SAG-D Isolation
- Pig Launcher & Receiver
- Mud Drilling Isolation & Check
- Lean & Rich Amine Isolation
- Molecular Sieve Regeneration Isolation
- Molecular Sieve Absorber Isolation
- First & Second Stage Separator Isolation





Hydrocarbon Refining

Coking (Delayed & Flexi)

- Switching
- Feed Isolation
- Overhead Vapor Line
- Cutting Water Isolation

Fluidized Catalytic Cracking

- Catalyst Handling
- Slurry Isolation & Control Steam

Ethylene

- Steam Decoke Isolation
- Furnace Isolation
- Steam Vent
- Quench Oil Isolation & Control

Polyethylene

- Isolation
- High Cycle (PTO)
- Reactor Block

Heavy Oil Upgrading & Hydrocracking (H-Oil & LC Fining)

- Catalyst Addition & Withdrawal
- Filter & Pump Isolation
- Overhead Vapor Isolation & Control
- High Delta-P Isolation & Control

Reforming (CCR)

- Lockhopper
- Isolation

Mining

High Pressure Slurry

Transportation Systems

- Pump Discharge Isolation
- Pipeline Isolation Stations
- Pipeline Choke Stations
- Rupture Disk Isolation
- Instrument Isolation

Autoclaves

- Vessel Feed & Discharge
- Acid Injection
- Gas Injection
- Steam Injection

Mineral Concentrators

- Thickener Underflow
- Discharge Isolation
- Filter Press Manifold Isolation
- Slurry Transfer Systems
- PRV Isolation

Waste Disposal

- Tailings Pipelines
- Paste Backfill

Pulp & Paper

- Boiler Vent & Drain
- Liquor Isolation & Control
- Rapid Drain
- Steam Isolation
- Sky Vents
- Dryer Pressure Control
- Digester Steam Control
- Lime Mud Isolation & Control



V1 Series

The Flagship of the ValvTechnologies Product Line.

The ValvTechnologies' design features are the implementation of extensive industry experience.

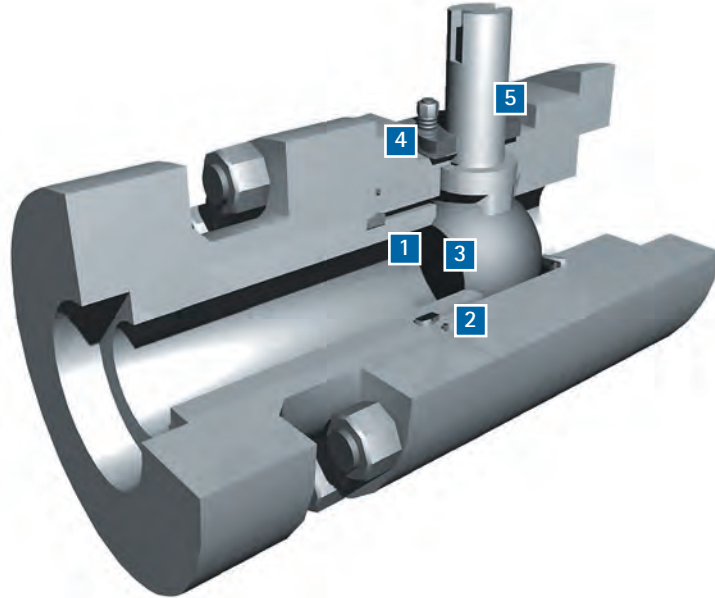

1 Integral Metal Seat.

With our patented Ceramet and Rocket Applied Metallic (RAM) coatings, the integral seat in ValvTechnologies' rotary operating valves are resistant from the attack of abrasive magnetite or ferrous oxides in the steam flow.

2 Body Seal Ring.

ValvTechnologies employs a field proven seal ring technology to ensure sealing under all operating conditions, up to 1400° F. The body seal ring is loaded at a pressure higher than 20,000 psi. In addition, valves sized 3 inch and above contain a secondary Grafoil seal to further guarantee reliability.

3 Patented Coating Process.

The sealing surfaces are overlaid with Tungsten or Chromium Carbide using our exclusive RAM® process. These surfaces have a hardness of 68 - 72 Rc to allow long periods of operation in the most severe conditions.

4 Live Loaded Gland Area.

The V1 Series gland packing design features a four stud, live-loaded assembly designed for heavy industrial applications. The packing material is high purity Grafoil® surrounded by Carbon Fiber / Inconel anti-extrusion rings. The six Bellville springs (per stud) provide constant load pressure through extreme thermal shocks and prevent wear leaks in high cycle service.

5 Blow-out Proof Stem.

ValvTechnologies design utilizes a one piece, hard-faced, blow-out proof stem that is inserted through the inside of the body cavity eliminating the possibility of blow-out through the gland area.



V1-1

**Forged, High Pressure Valves.
Four Year, ZERO Leakage Guarantee.**

- ANSI/ASME Class 900 - 4500
- 1/4 - 4 inch

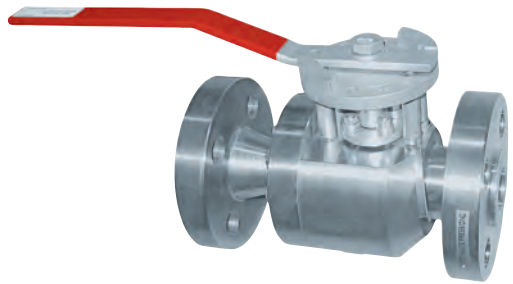

V1-2

**Flanged, Low Pressure Valves.
Four Year, ZERO Leakage Guarantee.**

- ANSI/ASME Class 150 - 600
- 1/2 - 36 inch



V1-3

**Small Bore, Investment Cast Valves.
Four Year, ZERO Leakage Guarantee.**

- ANSI/ASME Class 150 - 600
- 1/2 - 2 inch



V1-4

**Large Bore, High Pressure Valves.
Four Year, ZERO Leakage Guarantee.**

- ANSI/ASME Class 900 - 4500
- 4 - 36 inch

Zero Leakage Valve Solutions

PSG

**Parallel Slide Gate.
Bi-directional, ZERO Leakage Isolation.**

The ValvTechnologies Parallel Slide Gate Valve (PSG) addresses the need for true in line valve repairability in large diameter, high energy piping systems. Specifically designed for steam and feedwater applications, the PSG provides bi-directional, zero leakage using the RAM™ coating systems.



- ANSI/ASME Class 300 - 4500
- 6 - 36 inch
- Position Seated Easily Automated
- In-line Repairable
- Four Year, Zero Leakage Guarantee

ERV

**Electronic Relief Valve.
Protection of Safety Valves.**

ValvTechnologies' Electronic Relief Valve (ERV) fulfills the need for a zero-leakage, pilot-operated relief valve. The ERV package combines ValvTechnologies' zero leakage isolation valve with electronic controls to monitor and regulate system pressure. Whether in a capacity relieving function requiring the ASME V-Stamp or simply an overpressure protection application, the ERV provides reliable protection for standard safety valves in many industries. ValvTechnologies can also provide an integral isolation valve, eliminating the need for costly field welding. Standard blowdown and set pressure is accurate to 1/10%.



- ANSI/ASME Class 150 - 4500
- 1/2 - 12 inch
- ASME Sec. I, V-Stamp Capacity Certified
- Integral Isolation Valve Available
- Easily Adapted to Existing Controls
- Four Year, Zero Leakage Guarantee

XACTROL

**Characterized Trim.
Leak Free Isolation and Control in One.**

The XACTROL™ product group unites ValvTechnologies' zero-leakage technology with special designs that allow rotary modulating control. From the Mark I's design that features a characterized upstream seat to the Mark III's precision engineered stacked disks, the XACTROL™ allows the customer to combine precise flow control with tight shut-off. The XACTROL™ is typically used in applications where minimum flow and relatively high differential pressures are required.



- ANSI/ASME Class 150 - 2500
- 1/2 - 36 inch
- Integral, Characterized Downstream Seat
- Upstream Disc Inserts for Modulation

Turbine Bypass System

**Combined Cycle Plant Solution.
Facilitates Fast Start-up.**

The ValvTechnologies Turbine Bypass System (TBS) is designed for the new generation of combined-cycle power plants. It combines the XACTROL™ control valve design with a state-of-the-art desuperheating control system. The system allows the plant operator to keep the gas turbine and the HRSG online in the event of a steam turbine trip. The TBS also facilitates fast CT and HRSG start-ups in peaking power plants and allows these plants to operate at turndown conditions, far below the levels that can be achieved with standard governor systems.



NEXTECH™

The Next Generation in Trunnion Technology.

The advantages of the trunnion-mounted ball valve include: low operating torque, very high flow rates (Cv), protected sealing surfaces when in the open and closed position, and the ability to operate in the presence of solids and other contamination. The NEXTECH™ design from ValvTechnologies is designed to withstand severe thermal swings, meet stringent emission requirements, and provide long life in abrasive / erosive conditions.

The NEXTECH™ trunnion design provides a severe service solution for tough, high cycling applications.

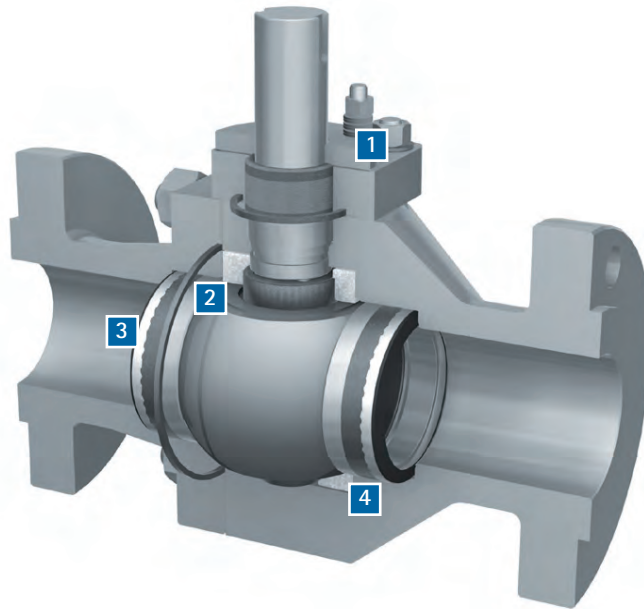

1 Live Loaded Gland Area.

NEXTECH™'s gland packing design features a four stud, live-loaded assembly designed for heavy industrial applications. The packing material is high purity Grafoil® surrounded by Carbon Fiber / Inconel anti-extrusion rings. The six Bellville springs (per stud) provide constant load pressure through extreme thermal shocks and prevent wear leaks in high cycle service.

2 Carbide Sealing Surfaces.

The sealing surfaces are overlaid with Tungsten or Chromium Carbide using our exclusive RAM® process. These surfaces have a hardness of 68 - 72 Rc to allow long periods of operation in the most severe conditions.

3 High Integrity Seat Surfaces.

To prevent leaks around the seats, ValvTechnologies has developed an innovative double seal design for high temperature operation and/or high cycling applications. In low temperature, high cycling service, a secondary elastomer seal is installed on the seat perimeter.

4 Solids Resistance.

In addition to the carbide coatings which will allow the valve to function in highly abrasive applications, the individual valve parts have additional seals to prevent interference from solids in the system. This provides for outstanding performance in catalyst systems, streams with solids contamination and polymers.

NEXTECH-1

**Low Pressure Trunnion.
Low Torque, Bi-directional Shut-off.**

ValvTechnologies' low pressure, trunnion-style, metal-seated ball valve incorporates many of the features of the traditional integral seat design into a lower-torque, bi-directional valve. The NEXTECH-1™ features a readily adjustable stem sealing design with a four-stud, live-loaded, industrial-grade packing gland assembly and offers diamond mate-lapped Tungsten or Chromium Carbide RAM™ coating on sealing surfaces. The NEXTECH-1™ is available in a variety of end connections to meet customer's specifications.



- ANSI/ASME Class 300 - 900
- 2 - 20 inch
- Low Pressure, Trunnion-Mounted

NEXTECH-2

**High Pressure Trunnion.
Block & Bleed, Bi-directional Shut-off.**

The ValvTechnologies high-pressure, trunnion-style, NEXTECH-2™ features a two-seat design that allows for a block and bleed, bi-directional shut-off. The optional top entry design for in line repairability and solids proofing allows the valve to work successfully in severe applications such as in high sulphur water and solids. The NEXTECH-2™ can be used in a variety of industries including Oil & Gas, Hydrocarbon Processing and Power.

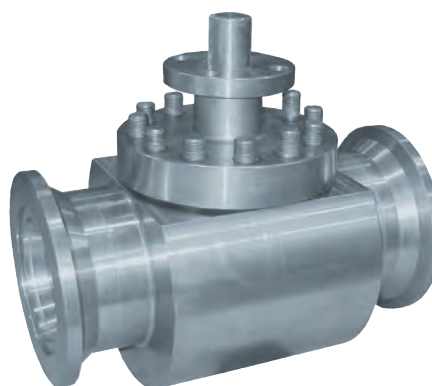

- API 5000, 10000, 15000
- ANSI/ASME Class 900 - 4500
- 2 - 36 inch

Specialty Valve Solutions

ABRASOCHECK™

High Pressure Positive Displacement
Pump Slurry Check Valve.

ValvTechnologies' ABRASOCHECK™ Slurry Check Valve is an upgrade of a product that has been used successfully in service for more than 30 years at the Savage River Iron Concentrate Pumping Plant in Tasmania. ValvTechnologies has re-engineered and improved the design of this product to be in line with our own technology for materials, coatings and manufacturing improvements. The combination of the ValvTechnologies ABRASOCHECK™ Slurry Check Valve and the ValvTechnologies ABRASOCHECK™ Slurry Ball Valve provides **zero leakage isolation** for maintenance of positive displacement pumps.



- ANSI/ASME Class 600 - 1500
- 4 - 24 inch
- Zero Leakage Isolation

ABRASOTECH™

Slurry Transport Solution.
Erosion & Corrosion Resistant.

The ValvTechnologies ABRASOTECH™ valve is the result of extensive experience in providing reliable valves for the transportation of slurries in cross country pipelines. With an installed base of over 4,000 slurry service valves worldwide, ValvTechnologies is the established leader in these applications. The ABRASOTECH™ valve is offered in carbon and stainless steel materials. The valves' internals can be protected against erosion and corrosion with the use of RAM™ coating and metallic or urethane liners.



- ANSI/ASME Class 150 - 2500
- 1/2 - 36 inch

Acid Injection Isolation

Designed for HPAL Service.
Emergency Shutdown Valve.

The ValvTechnologies Acid Injection Isolation Valve is a unique product created and designed for the isolation and emergency shutdown of HPAL autoclave acid injection systems. This valve uses ceramic seats, coatings and exotic metals to provide plant security in the harshest of process conditions.



- ANSI/ASME Class 150 - 900
- 1/2 - 4 inch
- Field Proven Design

3-Way Valves

Flow Diversion & Isolation.
Repeatable Tight Shut-off.

ValvTechnologies' metal seated 3-way valves are designed for the most severe applications where flow diversion is combined with the need for repeatable tight shut-off. The 3-way valve is available in 'T' and 'Y' configurations and in multiple combinations of body materials, trims and end connections.



- ANSI/ASME Class 150 - 4500
- Temperatures up to 1400° F / 760° C
- Tight Shut-off

Specialty Valve Solutions



Steam Choke Valve

Steam Injection Solution.
Field Proven to Last.

The ValvTechnologies steam choke is designed for the harsh conditions associated with steam injection. The rugged, maintenance-free steam choke features a self adjusting, double live-loaded design. The ValvTechnologies steam choke is most commonly used in thermal and water flood applications. Stable Flow rates are maintained due to stationary placement of the discs. This stationary positioning eliminates vibration and travel as well as greatly reducing flow turbulence. The ValvTechnologies steam choke is available in a variety of materials and end connections.



- ANSI/ASME Class 150 - 1500
- Temperatures up to 800° F / 427° C
- Wide Range of Flow Rates

Double Ball Valve

Bi-directional Isolation.
Back Pressure Protection.

Double Ball Valves (DB-2) fulfill the demanding needs for industrial applications where zero leakage isolation is required in bi-directional or double block-and-bleed valves. This valve is particularly useful when solids and high temperatures are present and can also be used in cases where space is limited. Two sealing units are required and one actuation device is preferred. The bi-directional version has the added advantage of back pressure protection. Even in very high pressure applications, this design prevents the sealing surfaces from separating.

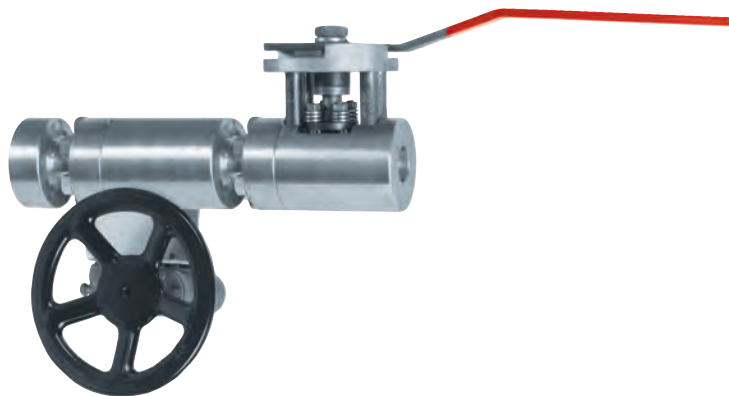

- ANSI/ASME Class 150 - 4500
- Temperatures up to 1600° F / 870° C
- One Actuation Device

Integral Block & Bleed

Two Isolation Points.
Class V Shut-off.

ValvTechnologies' Integral, Double Block & Bleed Valve is designed to provide unidirectional zero leakage shut-off, with **two isolation points in a single valve body**. Tight shut-off is confirmed by opening the bleed valve – guaranteeing a safe working environment downstream. Designed for and tested in steam service, the Integral Block & Bleed is available in a wide range of sizes, materials and end connections. It is easily automated with pneumatic, electric or hydraulic actuators – according to the customer's control specifications.



- ANSI/ASME Class 150 - 1500
- 2 - 36 inch
- Designed & Tested for Steam Service



Total Valve Management Program

Cycle isolation eliminates energy losses attributable to poorly performing or leaking steam, water cycle isolation valves.

ValvTechnologies encourages end users to apply the principles of Asset Management to their installed valve population. The ValvTechnologies Total Valve Management (TVM™) program, also known as Cycle Isolation, utilizes next generation acoustic monitoring instruments to help customers monitor valve performance. These tools allow predictive and preventative maintenance programs to be fine tuned for very large or very small valve populations. Providing Cycle Isolation Services can be as simple as performing a valve survey, or as comprehensive as the management of all valve work during your next outage – from erecting scaffolds to repairing, installing, welding and stress relieving.

ValvTechnologies' Program Highlights:

- **1% – 3% in Plant System Efficiency Increase**
- Highest Rates of Return on Investments
- Ease of Execution
- Fast Results with Minimal Effort Required
- Non-Intrusive to Plant Operations
- Overall Reductions in Valve Maintenance Costs

Eliminating cycle energy losses on the Critical Loss or High Priority Replacements alone will result in a **0.22% reduction in emissions levels.**

Factory Authorized Service Centers

ValvTechnologies is committed to helping our global network of customers maintain peak valve performance. ValvTechnologies has multiple authorized service centers located around the world that are available **24 hours a day, 7 days a week** to assist with valve installation, commissioning, troubleshooting and actuator maintenance.

North America

ValvTechnologies, Inc. - Texas
+1 713 860 0400

Celtex Industries - Texas
+1 903 297 8481

Puffer Sweiven, Stafford - Texas
+1 281 470 2000

Puffer Sweiven, La Porte - Texas
+1 409 736 2861

Nichols-Given Associates, Inc. - Colorado
+1 303 773 1401

American Valve & Pump - Florida
+1 863 709 0455

Carter Chambers - Louisiana
+1 225 926 2236

Power House Supply - Massachusetts
+1 978 499 9000

Swanson Flo-Systems, Co. - Minnesota
+1 763 383 4700

Control Associates, Inc. - New Jersey
+1 201 934 9200

Speciality Valves & Controls - North Carolina
+1 704 522 9873

Trivaco - Ohio
+1 513 697 9890

GSB Inc. - West Virginia
+1 304 562 3304

CG Industrial Specialties - Canada
+1 780 462 1014

Africa

Spirax Sarco SA (Pty) Ltd - South Africa
+27 (11) 230 1300

Asia

Beijing Carve Out Valve Equipment Co. - China
+8610 51717896

Australia & New Zealand

Flotech Controls Pty Ltd - Australia
+612 9949 4888

Europe

SMRI - France
+33 04 42 13 00 80

Argo International Europe Ltd - Italy
+39 055 420 6047

DS Controls - Russia
+7 (8162) 15 79 28

MCE plc - United Kingdom
+44 (0) 1642 882211

South America

ValvTechnologies - Brazil
+55 12 3322 6527

Saltex Chile S.A. - Chile
+562 7304700

ValvTechnologies - Peru
+51 1 628 1126

Puffer Sweiven - Venezuela
+58 261 7573410 / 8445



Zero Leakage Valve Solutions

Corporate Capabilities



Corporate Offices & Manufacturing

Headquarters

ValvTechnologies, Inc.
5904 Bingle Road
Houston, Texas 77092 U.S.A.
Telephone +1 713 860 0400
Fax +1 713 860 0499
sales@valv.com

To locate a distributor or satellite office near you, visit us online at: www.valv.com

Argentina / Chile / Peru

Lima
+51 1 628 1126
peru@valv.com

Brazil

Sao Paulo
+55 12 3322 6527
brazil@valv.com

China

Beijing
+86 135 1107 1907
china@valv.com

Chengdu

+86 28 8631 7266
china@valv.com

Shanghai

+ 86 21 5383 9881
china@valv.com

United Kingdom

Stockton on Tees
+44 1642 882211
europe@valv.com

Middle East

Kingdom of Bahrain
+973 17 735758
middle.east@valv.com

